

WARRANTY

Bacharach, Inc. warrants to buyer that at the time of this product will be free from defects in manufacture, and will conform substantially to its applicable specifications. Bacharach's liability under this warranty are limited to repair or replacement, at Bacharach's option, of product or parts thereof returned to Seller at the manufacturer and shown to Bacharach's reasonable opinion to have been defective; provided that written notice of the defect shall have been given by Buyer to Seller within one (1) year after the date of delivery of product by Bacharach.

Bacharach warrants to Buyer that it will convey good title in this product. Bacharach's liability and Buyer's remedy under this warranty of title are limited to the repair of title defects or, at the election of Bacharach, replacement of this Product or parts thereof that are defective in title.

This warranty set forth in paragraph 1 does not apply to the Operating Instructions designate as having a limited life or as being expended in normal use.

THE FOREGOING WARRANTIES ARE EXCLUDED AND ARE GIVEN AND ACCEPTED IN LIEU OF ALL OTHER WARRANTIES, EXPRESS OR IMPLIED, INCLUDING WITHOUT LIMITATION IMPLIED WARRANTIES OF MERCHANTABILITY AND FITNESS FOR A PARTICULAR PURPOSE; AND NO OBLIGATION, LIABILITY, RIGHT, OR REMEDY IN CONTRACT OR TORT, WHETHER OR NOT ARISING FROM BACHARACH NEGLIGENCE, ACTUAL OR IMPLIED. The Buyer shall be limited to those provided the exclusion of any and all other remedies in without limitation incidental or consequential. No agreement varying or extending the foregoing, remedies or this limitation will be binding on Bacharach unless in writing, signed by a duly authorized officer of Bacharach.

The Smoke Scale, Filter Paper, Valve Disc, and Pump Lubricant are expendable items and are excluded from this warranty.

Parts List for TRUE-SPOT® Smoke Tester (0021-7012)

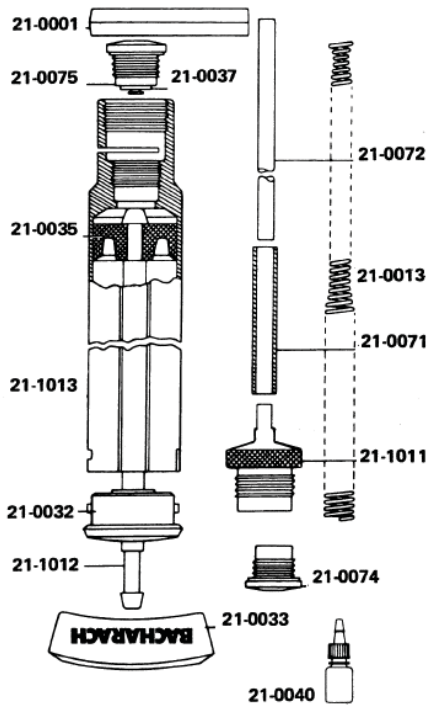

ITEM	NUMBER REQUIRED	CODE NUMBER
Clip	1	0021-0001
Sampling Tube	1	0021-0072
Spring	1	0021-0013
Rubber Hose	1	0021-0071
Smoke Scale (not shown)		0021-0018
Filter Paper (not shown)		0021-0019
Check Valve Assembly (Includes 0021-0037)	1	0021-0075
(Valve Disc only)	1	0021-0037
Cylinder	1	0021-1013
Trap	1	0021-0074
Clamp Screw	1	0021-1011
Cylinder Cap	1	0021-0032
Handle	1	0021-0033
Rod	1	0021-1012
Cup	1	0021-0035
Pump Lubricant (1/4 Fl. Oz.)	1	0021-0040
Wrench (not shown)		0021-0078

INSTRUCTIONS and PARTS LIST for TRUE-SPOT® Smoke Tester (0021-7012)

INSTRUCTION 0021-9012
Rev. 2 - June 2010

Bacharach, Inc.
621 Hunt Valley Circle
New Kensington, PA 15068
Phone: 724-334-5000
Fax: 724-334-5001
Web: www.mybacharach.com



OPERATING INSTRUCTIONS for Testing Oil Burners

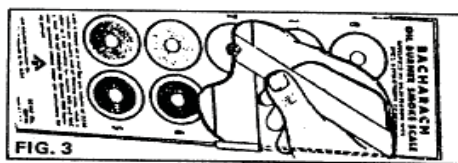
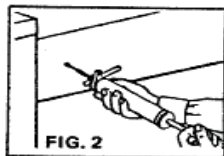
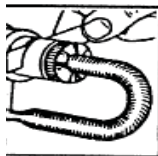

strip from perforated Filter Paper sheet (in SCALE envelope); loosen Clamp Screw, insert taper strip in slot (Fig. 1) and tighten Clamp Screw. Remove Sampling Tube from rubber barrel Clip.

Insert Sampling Tube at least 2 1/2 inches into flue 9/32 inch diameter hole located between furnace flue outlet and draft regulator.

Insert TRUE-SPOT Handle through TEN (10) full oke (Fig. 2).

Remove Sampling Tube from flue, loosen Clamp Screw and remove Filter Paper.

OBSERVE THESE SUGGESTIONS FOR MAXIMUM ACCURACY

Although TRUE-SPOT (0021-7012) has been modified for addition of condensation Trap and Check Valve, it is still good practice to warm a cold TRUE-SPOT room temperature before testing begins. This prevents moisture buildup in condensate traps.

At every 10th sample, tap Sampling Tube to prevent rust, tighten Clamp Screw without Filter Paper and purge with several rapid pump strokes.

During sampling be sure to pull piston through 10 oke and hold for several seconds at end of each stroke.

MAINTENANCE INSTRUCTIONS General

The design of Model 0021-7012 TRUE-SPOT makes maintenance and replacement of worn or damaged a simple matter. Maintenance includes emptying condensate traps if necessary, checking for leak-periodic cleaning and lubrication. Replacement may be ordered from the Parts List while specific maintenance instructions are discussed in detail in the following sections.

1.

(5) Match color of smoke spot on Filter Paper strip to the closest spot on 10 spot OIL BURNER SMOKE SCALE (RR-776). In comparing color of smoke spot to chart, slide Filter Paper strip between back of SMOKE SCALE and white plastic slide, viewing smoke spot on Filter Paper through window in center of color spots on SMOKE SCALE with smoke spot backed by white plastic slide (Fig. 3).

(6) Take additional samples required by clamping Filter Paper strip in slot so previous spot is visible outside the slot.

On pull stroke, use a steady pull motion such that a full stroke is obtained in 3 or 4 seconds.

(d) Check TRUE-SPOT occasionally for leakage (SEE MAINTENANCE INSTRUCTIONS).

(e) For maximum accuracy, hold SMOKE SCALE at arm's length from eyes when comparing smoke spot on Filter Paper.

(f) Keep SMOKE SCALE clean and store in envelope provided when not in use.

2.

MAINTENANCE, cont'd.

the Clamp Screw holds condensed moisture which would normally wet Filter Paper on intake stroke. When Traps are filled with excess condensate as indicated by Filter Paper wetting, Traps should be removed for cleaning. Remove both Traps with the wrench provided.

(b) Traps should be shaken and/or blown out. The Valve Disc may be removed to facilitate this operation when cleaning Check Valve Assembly. When replacing Valve Disc, make sure stepped side of Disc faces inward.

(c) All surfaces adjoining Traps and Filter Paper should be dried with a clean cloth, or reassemble and tighten Clamp Screw without Filter Paper in slot and pull pump Handle through 10 or 15 full pump strokes (room air).

2. Leakage

To check TRUE-SPOT for leakage on Pump Cylinder side of Filter Paper, clamp piece of hard cardboard securely in slot. Pull Handle out about one inch and release. TRUE-SPOT Handle should return to approximately original position. Failure to do so indicates TRUE-SPOT leak caused by rubber Cup or loose Check Valve Assembly.

3. If TRUE-SPOT Leaks

(a) To examine rubber Cup for damage, turn Cylinder Cap counterclockwise and pull plunger out of Cylinder. Plunger should be rotated slowly at end of stroke to prevent possible damage to rubber Cup due to burrs on Cylinder Cap retainer slots. If Cup shows sufficient wear or damage to cause leakage, replace as described under PARTS REPLACEMENT.

(b) If Cup shows only slight wear, relubrication as described in Section 6 will stop leakage.

(c) To examine Rubber Hose connecting pump to metal Sampling Tube, first tighten Clamp Screw securely; then turn coiled guard Spring clockwise off connection at pump. Replace defective hose with Bacharach part no. 0021-0071.

4. Parts Replacement

The complete TRUE-SPOT Assembly can be dismantled for cleaning or parts replacement with the exception of the Handle (0021-0033) and Cup (0021-0035). Removal of either of these two parts from the Rod for any reason except replacement is not advised. Damage to the rubber parts will occur as a result of forced removal.

If Handle or Cup must be replaced, cut the rubber part in need of replacement away from Rod. Install replacement by pressing tapered end of rod through hole

3.

in rubber piece until retaining shoulder is engaged. MAKE CERTAIN CUP OR HANDLE IS ORIENTED ON ROD CORRECTLY AND CYLINDER CAP IS IN PLACE BEFORE FINAL ASSEMBLY.

5. Cleaning TRUE-SPOT

TRUE-SPOT should always receive a complete cleaning prior to renewal of lubrication (see Section 6), but individual parts should be cleaned as required.

To thoroughly clean TRUE-SPOT, instrument should be completely torn down. Do not remove Handle or Cup except under conditions outlined in Section 4. An approved degreasing safety solvent may be used to clean old lubricant from Cup and Cylinder bore.

WARNING: Always take precautions and follow manufacturer's directions when using solvent. To clean Cylinder, saturate a swab with solvent and work into bore until free of encrusted lubricant.

Remove Valve Disc (0021-0037) from Check Valve Assembly. Clean and make certain ports are clear. When replacing Valve Disc, make sure stepped side of Disc faces inward.

Condensed flue gas which has formed a deposit on the Rod should be removed by scraping or sanding with emery cloth. This will prevent Cylinder Cap wear which results from Rod working against hole in Cylinder Cap.

6. Relubricating TRUE-SPOT

Tendency for TRUE-SPOT to "pull hard" at a sampling speed of 3 to 4 seconds per stroke with Filter Paper in place is usually due to lack of lubrication. Clean TRUE-SPOT thoroughly as described above before lubricating.

Bacharach Pump Lubricant (0021-0040) has been selected for superior lubricating qualities, viscosity, chemical inertness, and long life. Substitutes are not advised.

Best means of applying is to spread enough lubricant around the outside of the Cup so that when Cup is wrapped with one layer of muslin cloth, lubricant is squeezed through fabric weave. Any thin, lint-free fabric including muslin is satisfactory.

Insert lubricated and fabric wrapped Cup into Cylinder bore and work back and forth until a thin film of lubricant remains on the bore. It will probably be necessary to apply more lubricant to the Cup, rewrap, and repeat the procedure several times before a satisfactory thin, even film remains. Do not apply too much lubricant, or seepage will result when TRUE-SPOT is stored.

After Cylinder bore is lubricated, work lubricant remaining on muslin cloth onto outer rim of Cup and reassemble TRUE-SPOT.

4.