

DAIKIN



No. AT05C052E

Sep.9.2011

SPECIFICATIONS

COMPRESSOR

MODEL : JT160G-P8Y1

1. Range of Application and Assembly

1-1 Applied Range

The specifications provided here apply to the JT160G-P8Y1 Hermetic Scroll Compressor.

1-2 Range of Assembly

	Name	Quantity	Plan No.	Remarks
1	Compressor	1	DA430-253	Including lubricant
2	Anti-vibration Rubber	4	DA429—903—1	
3	Spacer	4	DA429—903—2	

Note: The pressure units in these specifications refer to the gauge pressure, unless stated otherwise

2. Main Specifications

2-1 Ratings

Item		JT160G-P8Y1
Rated Output	kW	3.75
Number of Poles	-	2
Displacement	cm ³ /r	56.8
Rated Speed(=Nominal Revolution)	r/min	2900 [50Hz]
Lubricant	-	DAPHNE FVC68D
Lubricant(Volume)	cm ³	1500
Refrigerant	-	R410A
Inlet Pipe (I.D)	mm	19.17 ~ 19.32 (C1220T—O)
Outlet Pipe (I.D)	mm	16 ~ 16.15 (C1220T—O)
External Cable Terminal	—	AMP 42232-3
Weight (including refrigeration oil)	kg	38.5
Power Supply	—	3 phase at 50Hz
Rated Voltage	V	380 ~ 415

3. Quality Specifications

3-1 Appearance and Dimensions

- The entire surface of the compressor has been coated with black paint (dipping and quick-dry painting). (coating membrane thickness is 15 μ m, at least)
- Outer dimensions are shown on the attached diagrams of the exterior.

3-2 Leak Test and Pneumatic Resistance Test

The leak and pneumatic resistance tests of the compressor are conducted under the following conditions.

	Low-pressure side [MPa]	High-pressure side [MPa]
Leak Test	3.3	4.17
Pneumatic Resistance Test	15.0	15.0

3-3 Compressor Characteristics

Frequency	Voltage	Refrigerating Capacity	Input	Current	COP	Sound Pressure	Vibration
[Hz]	[V]	[kW]	[kW]	[A]	W/W	[dBA]	[μm]
50	380	16.69	4.85	8.3	3.5	59max.	50 max.

Note 1. The characteristics tests of the compressor are conducted under one of the following conditions.

Evaporating Temperature [°C]	Condensing Temperature [°C]	Superheating Degree [°C]	Super-cooling Degree [°C]	Environment temperature [°C]
7.2	54.4	27.8	8.3	35

2. The refrigerating capacity, input, and current fluctuation within a range between 95% and 105%.
3. The sound pressure value is measured for the position one meter in front of the compressor at a height half , in use Daikin's genuine rubber mounting.

4. The vibration value is measured at the compressor legs attached, in use Daikin's genuine rubber mounting.

3-4 Starting Characteristic

- Starting Current (LRA) : 59.2/63.0/65.8A (380/400/415V 50Hz)

Note : LRA means locked-current after starting 4s.

- Starting Voltage : Minimum terminal voltage of 323V (50Hz)
- Starting Pressure : 2.6Mpa (high pressure, Max.)

3-5 Motor Characteristic

- Coil Resistance : 2.83 (average) at 20

3-6 Electric Characteristic

- Insulation Resistance : 30 M min. (when dry), 1 M min. (when refrigerant flood the compressor.)
- Withstand Voltage : 2,400V AC for 1 sec. and no dielectric breakdown impress
- Leakage Current : 0.75 mA/ kW Max.

3-7 Others

- Moisture content : 500 mg Max.
- Residual chlorine amount : 15ppm max.(for the standard oil charge of 1100cm³)
- Residue : 50 mg Max.
- The compressor is filled up with nitrogen gas at a pressure of 0.01MPa before shipping.

4. Compressor Operating Range

4-1 Operating Range

Refer to page 6 for the Compressor Operating Range.

4-2 Precautions

1) Don't drive under air condition, otherwise may cause the compressor explosion.

2) Temperature

- Discharge port temperature : 130°C Max.
- Discharge gas temperature range : 120°C Max.
- Oil temperature : 120°C Max.
- Motor winding temperature : 125°C Max. (Average temperature based up on resistance measure of motor coil)

3) Power Supply

- Maximum voltage fluctuation : ±10% of rated voltage
- Phase imbalance : ± 2.5%
- Maximum frequency fluctuation : ±2% of rated frequency

4) Refrigerant Systems

- Allowable refrigerant charge : 2.4 kg

Liquid compression and liquid impact : No

The compressor may be filled with an excessive refrigerant charge, provided that circuit design is conducted with an appropriate device, such as an accumulator, is employed so that the compression mechanism will be free of excessive refrigerant. Please estimate liquid or impart by unwonted sound of the compressor.

- Be sure to keep the discharge port temperature upon condensing temperature.

- Oil concentration in oil sump during operation: 35wt% Min.
- The compressor must be filled with refrigerant through the liquid pipe.
- If the liquid height of residual compressor oil and refrigerant maintained in the compressor above external bottom higher than 281mm, the part of terminal will immerse in the liquid of residual compressor oil and refrigerant. In that case, insulation resistance of the compressor will fall. Therefore, please design the refrigerant pipeline so that liquid height of residual compressor oil and refrigerant maintained in the compressor above external bottom lower than 281mm.
- Design the refrigerant pipeline so that the oil in pipeline return to compressor rapidly.
- Make sure that the moisture content in liquid refrigerant under 75ppm.
- Counter pressure (i.e. Suction pressure – discharge pressure) at pneumatic or leak test
 - : 1.47MPa Max.
- Maximum operating times : 12 per hour Max.

Make sure that the shortest operation period is two minutes or more. Be sure to wait for at least three minutes to start the compressor after turning it off.

- Mounting Angle : $\pm 10^\circ$ Max.
- Be sure to employ a crankcase heater. The recommendable output is 33 W.
- Liquid height of residual compressor oil during operation should be maintained in the compressor external bottom at, at least, 27mm.

5) The control of the residue inside the refrigerating system

- Allowable water content : 150ppm max. (in liquid refrigerant)
- Allowable air infiltration amount : 500ppm max. (charged oil weight ratio)
- Allowable chlorine amount : 25ppm max. (charged oil weight ratio)
- Ester oil infiltration : 6000ppm max.(charged oil weight ratio)
- Although oil remaining in air conditioner system is recommended to be at 6000ppm below, capillary jam test should be done. If not, our company are not responsible for the breakdown such as capillary jam etc, we kindly hope you comprehend and support.
- The accumulator and receptor must be cleaned, without press oil and rust-proof containing metals soap etc.
- Please apply the pipe and function parts (Such as four way valve and other parts)in which residue is controlled.(The residue means oil and solid remains)

5. Protection Devices

When the compressor is installed in an air-conditioner system, it must be installed with the following protection devices.

5-1 Discharge Pipe Thermostat

Attach a discharge pipe thermostat within 30 cm of the discharge pipe in order to prevent the temperature of the exhaust gas of the compressor from rising excessively due to overloading or gas supply interruption. The thermostat must be set at temperature less than the maximum stipulated in 4.2.2). (reference value: $120 \pm 0.5^\circ\text{C}$).

5-2 Low Pressure Switch

Attach a low-pressure switch operating at a low pressure of $0.02 \pm 0.02\text{MPa}$ in order to prevent the compressor from damage that may be caused by excessively low-pressure pumping.

5-3 Reverse-Phase Protector

The rotation of the compressor in the reverse direction is prohibited because the compressor may be damaged if rotated in the reverse direction. Attach a reverse-phase protector that detects the phase inversion of the compressor without operating the compressor.

5-4 Internal Motor Protector (that had already been installed in the compressor)

- Manufacturer : UBUKATA INDUSTRIES CO., LTD
- Model : UP18WA163-44G
- Temperature Characteristics : Open Temperature 180°C ± 5°C
: Close Temperature 70°C ± 10°C
- Electrical Characteristics : Power supply Voltage 380V~415V
: Power supply Frequency 50Hz
: Trip performance Specified In Page 10/17
: Maximum Electrical Capacity 75A(380V)

5-5 Over-current Relay

Over-current relay shall be installed in order to prevent compressors from accident that may be caused by over-current especially locked-current of compressor motor.

5-6 High Pressure Switch

In order to interrupt the operation of the compressor in the case of extraordinary pressure rises, attach a high-pressure switch that operates at the pressure values provided as leak test pressure values in 3-2. (Reference value:4.07 ~ 4.17MPa).

6. Deadening and Otherwise

The hot-proof temperature of deadening and otherwise entwining compressor must be upon 170°C.

The hot-proof temperature of scarfskin of power supply cable contacted with compressor must be upon the temperature of contacting position.

7.Performance Curves

Reference to the accessional datum.

8. Origins and Factory

Xi'an Daikin Qing'an Compressor Co., Ltd. (IN CHINA)

9. Possible Compressor Operating Range

- Refer to 9-7 on the following page for the possible compressor operating range.
- Possible operating range is divided into four areas (areas 1~4). The attendant conditions for each differ.
- Operate the compressor upon sufficient confirmation of the following attendant conditions, particularly for areas 2, 3 and 4.

9-1 Area 1

Observe the precautions in 4-2.

9-2 Area 2

Specifically confirm the following from the precautions in 4-2 :

- Discharge port temperature : 130 Max.
- Motor coil temperature : 125 Max.(Average temperature based up on resistance measure of motor coil)
- Oil temperature : 120 Max.

- Oil concentration : 35wt% Min.

9-3 Area 3

Specifically confirm the following:

- Oil concentration : 35 wt% Min.
- Liquid compression : No liquid compression

9-4 Area 4

Specifically confirm the following:

- Continuous operating time : 10 minutes max.
- Oil concentration : 35wt% Min.
- Liquid compression : No liquid compression
- Discharge port temperature : 130 Max.
- Motor coil temperature : 125 Max. (Average temperature based up on resistance measure of motor coil)

9-5 Start

When starting the compressor , The following items must be complied with :

- Complying with the following condition

$$\int_0^{20} \Delta P(t) dt \geq 0.45 [MPa \cdot s]$$

t: Start time (s)

P : pressure difference changing With time (MPa)

9-6 Pressure difference when continuous running

When compressor is continuously running (includes condition change) ,the pressure difference must comply with the following items:

- Pressure difference is over 0.2 MPa. If the pressure difference can not be provided , continuous running time of the compressor is not permitted over 10min. , and the pressure difference must be more than 0.04MPa .
- When four-way valve switching happens under the condition of defrosting start and end ,etc., the pressure difference must be more than 0.04MPa within 20 seconds.

9-7 Possible Compressor Operating Range

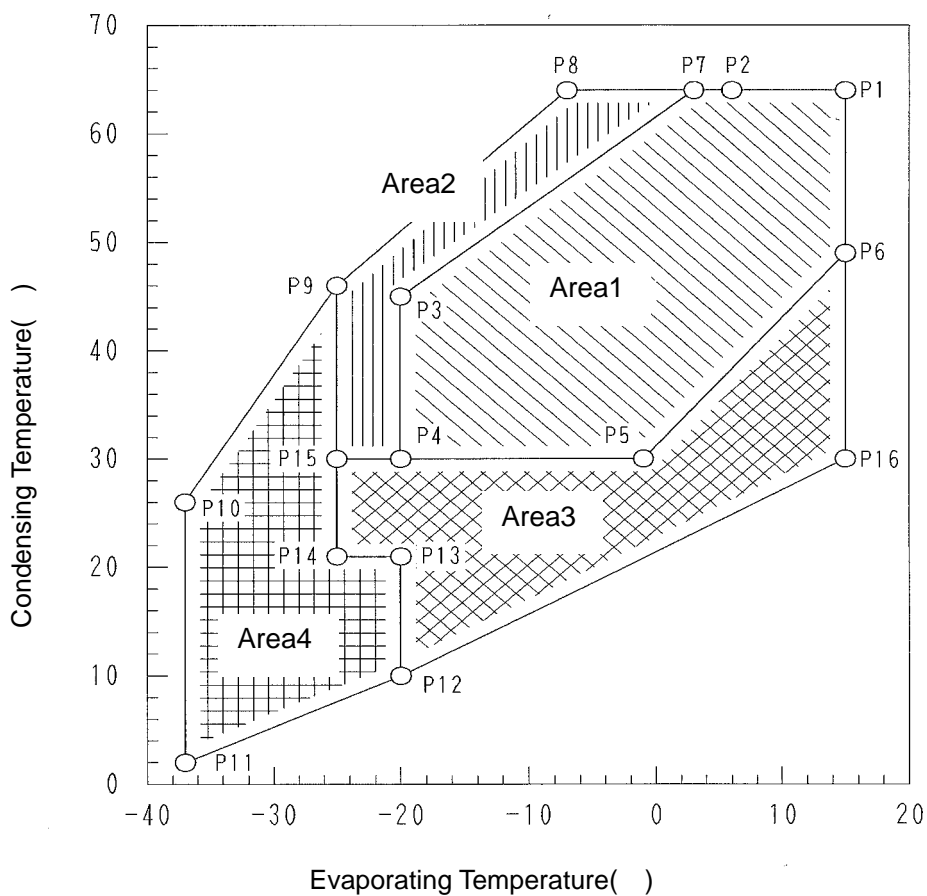

Point	P1	P2	P3	P4	P5	P6	P7	P8
Evaporating Temperature()	15	6	-20	-20	-1	15	3	-7
Condensing Temperature()	64	64	45	30	30	49	64	64

Point	P9	P10	P11	P12	P13	P14	P15	P16
Evaporating Temperature()	-25	-37	-37	-20	-20	-25	-25	15
Condensing Temperature()	46	26	2	10	21	21	30	30

Nameplate

The nameplate on the compressor will appear as follows.



<Guide>

- | | |
|-------------------|--------------------------------|
| • MODEL | A: Model Name |
| • POWER SOURCE | |
| V | B: Rated Voltage |
| PHASE | C: Phase number |
| Hz | D: Rated frequency |
| • MFG.NO. | E: Manufacturing number |
| • REFRIGERANT | F |
| PHASE ARRANGEMENT | |

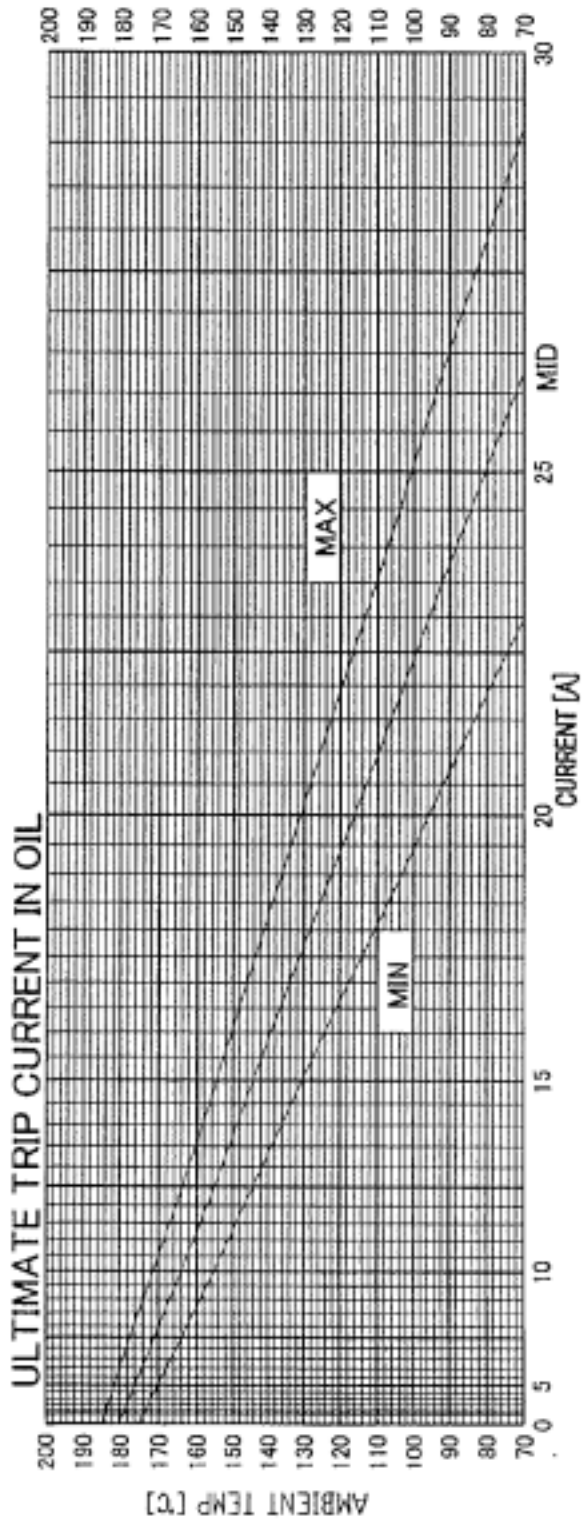

TYPE

UP18WA163-44G



4. UBUKATA INDUSTRIES CO., LTD
PHONE 06-412-8881 FAX 06-412-8886

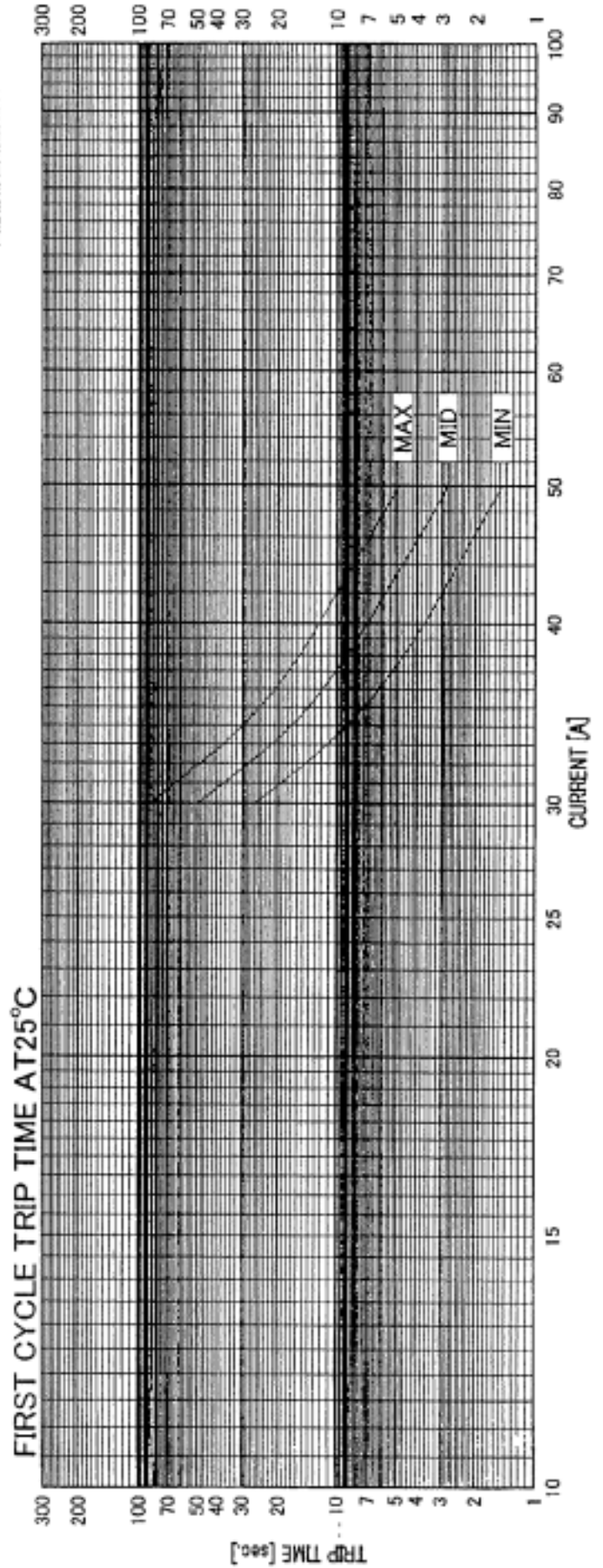

While install the compressor, Setting position of protection devices must be attention.

- Protection Devices : Low Pressure Switch
- High Pressure Switch
- Discharge Pipe Thermostat

	Setting Position	Notice
Low pressure switch	Compressor ~ Accumulator	Confirm discharge port temperature
High pressure switch	Compressor ~ Four-way Valve	
Discharge pipe thermostat	Distance from discharge pipe is 30cm (max)	Confirm discharge port temperature

Notice: The setting position must possibly close to the compressor.

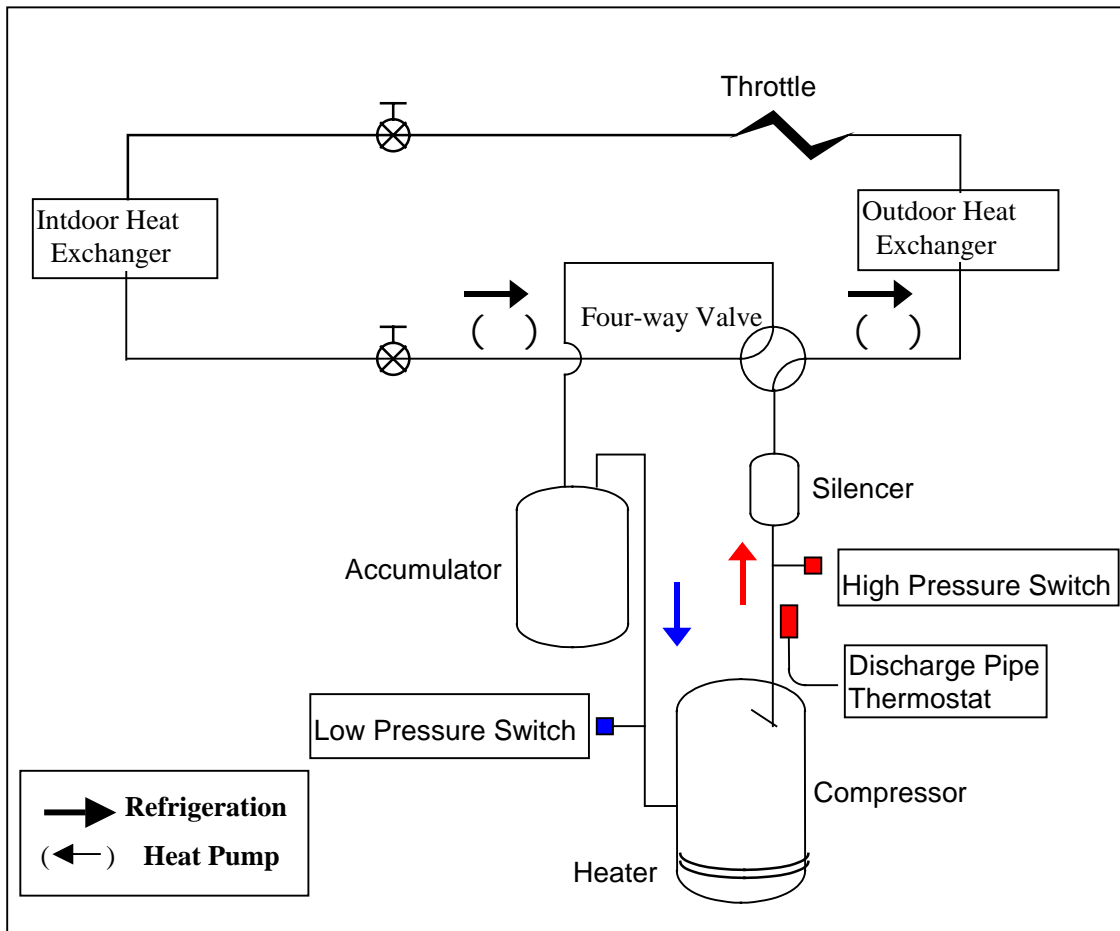

Reverse-Phase Protector

(1 : Operating Condition)

	Item	Used Condition
1	Installation Site	Inside Control Box of Indoor or Outdoor System
2	Operating Temperature	- 20 ~ 65
3	Storage Temperature	- 25 ~ 70
4	Humidity	Maximum Range 98%R.H., under 80%R.H. Year Average, under 80%R.H at 60 .Capable fluctuating Temperature or Humidity.

(2 : Specification)

	Item	Specification
1	Model	RPJ-400V
2	Function	Make: Positive – Phase – Sequence Break: Negative – Phase - Sequence
3	Rated Main Circuit Voltage	R-S-T1 AC 346V ~ 380V(3 Phase) R-S-T2 AC 400V ~ 440V(3 Phase)
4	Time Rating	Continuous
5	Output Contact Rating	AC 250V Inductive Load Making 8A(Pf=0.65), Breaking 2A(Pf=0.4) Resistive Load 3A(Pf=0.95 MIN.)
6	Life	10000 Times MIN.
7	Weight	37g
8	Applicable Mounting Spacers	XGLS-8S (Made By KITAGAWA INDUSTRY CO., LTD.) 4 pieces

(3 : Dimension Diagram)

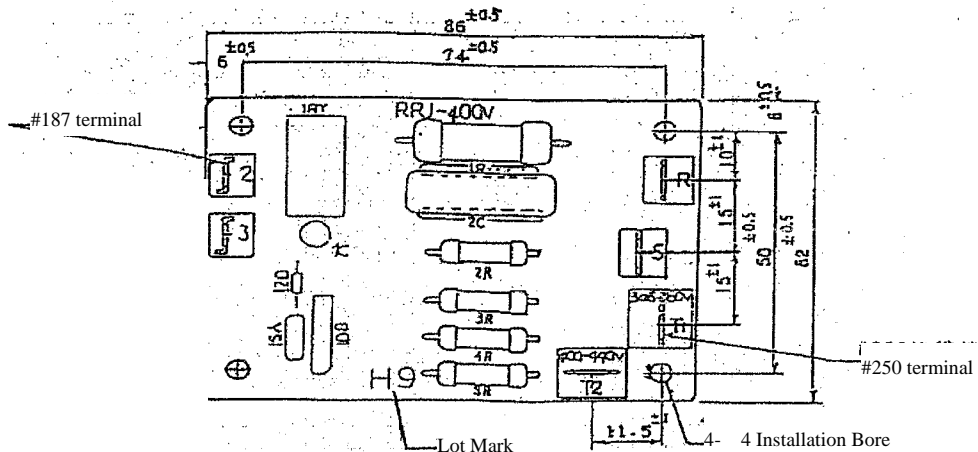

Stamp Color: Black

2C Capacitor: Fixed by Binder
Binder is made by SIMITOMO 3M, JAPAN. Product model : 3748.

(4 : Circuit Diagram)

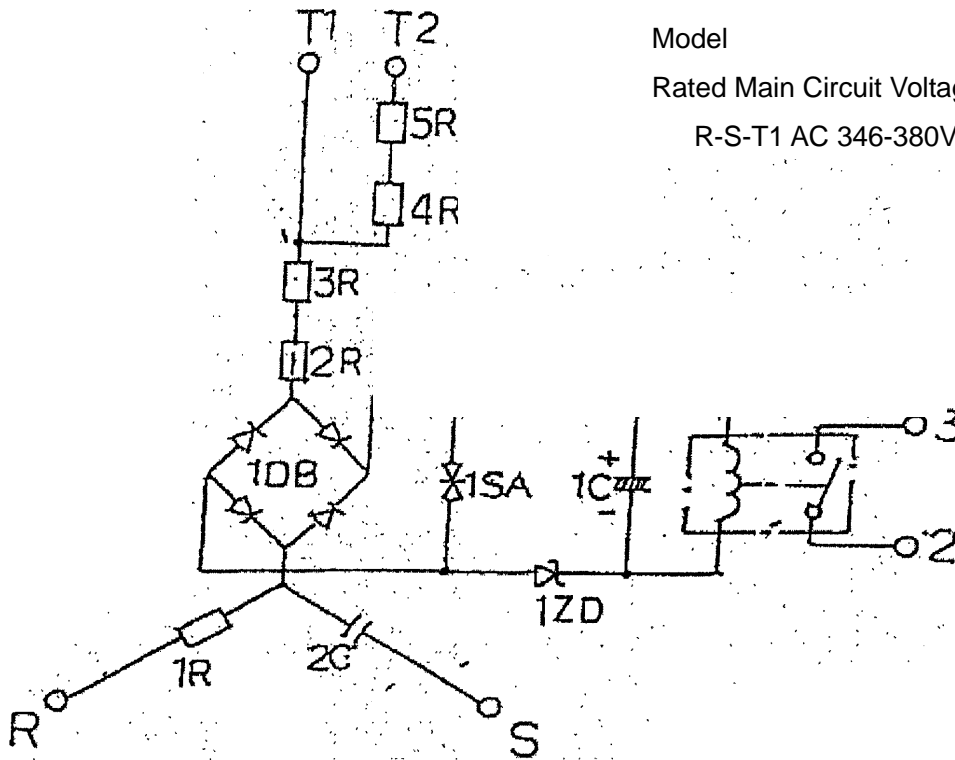

Model : PRJ-400V
 Rated Main Circuit Voltage :
 R-S-T1 AC 346-380V(50/60 Hz)

5 : Parts Table

.	Parts Name	Mark	Quantity	Specification
1	Resist-Oxidation Metal-film Resistor	1R	1	3W 82k
2	Resist-Oxidation Metal-film Resistor	2R	1	2W 5.6k
3	Resist-Oxidation Metal-film Resistor	3R	1	2W 5.6k
4	Resist-Oxidation Metal-film Resistor	4R	1	2W 5.6k
5	Resist-Oxidation Metal-film Resistor	5R	1	2W 5.6k
6	Electrolytic Capacitor	1C	1	50V 22 μ F
7	Metallized Polyester film Capacitor	2C	1	AC600V 0.039 μ F
8	Diode Subassembly	1DB	1	200V 1A
9	Rheostat	1SA	1	120V
10	Low-Voltage Diode	1ZD	1	500mV 24V
11	Relay	1RY	1	G6B-1114P-US, DC 24V(OMRON)
12	Printed Circuit Board	-	1	CEM-3, 94V-O
13	Terminal (#250)	-	4	Tinned Brass (0.8 T)
14	Terminal (#187)	-	2	Tinned Brass (0.5 T)

CAI/2018
 富士通製油
 FUJITSU OIL PRODUCT

機種名 MODEL	JT170G-P8Y1	JT160G-P8Y3
定格出力 RATED OUTPUT (kW)	4.5	3.75
巻線方式 WINDING SYSTEM	60.5	50.5
回転数 ROTATIONAL SPEED (RPM)	2900	
油潤滑 REF. OIL GRADE	DAPHNE HVGG80	
油潤滑量 REF. OIL GRADE (L)	1.5	
圧縮機 REFRIGERANT	R410A	
圧縮機仕様 SECTION CODE	#19.1 I.D.	
吐出管径 DISCHARGE DIA.	#15.8 (I.D.)	
吐出管長さ DISCHARGE LENGTH	30.8	
電源 POWER SUPPLY	3 PHASE 50HZ	
電圧 VOLTAGE RANGE (V)	380-415	

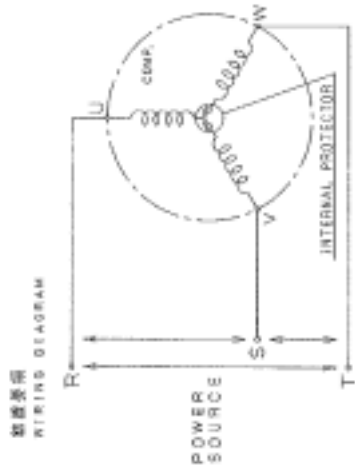
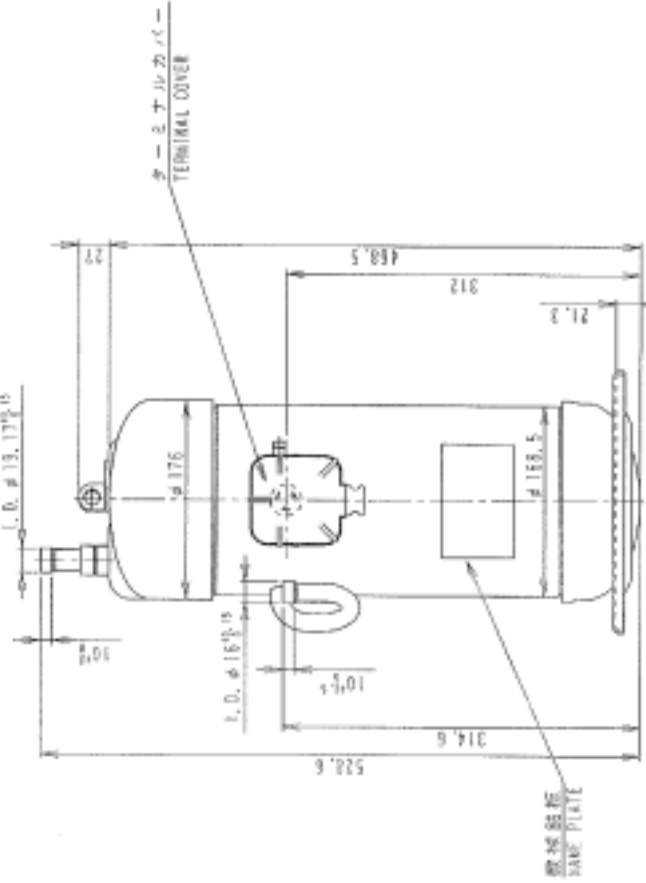
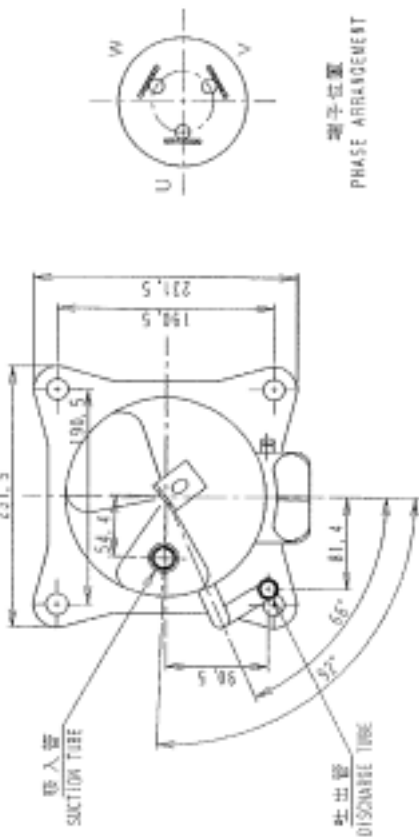

DA430-253

CCW
 2

SHIMADZU
 (株) 西川
 00-10-20-
 50-60-78

西川

尺 寸 SCALE	1:1
作 業 日 DATE	05.12.16
製 造 者 MFG. CO.	西川
製 造 所 MFG. PLANT	山形
製 造 年 月 MFG. YEAR	2018
製 造 品 名 PART NAME	DA430-253
製 造 品 番 PART NO.	120100
製 造 品 名 PART NAME	DA430-253
製 造 品 番 PART NO.	120100

JT170G-P8Y1 外形図
 OUTLINE DRAWING

Crankcase Heater

- Install crankcase heater along weld mark upper as follow fig.
- Please don't let Crankcase heater cover the weld mark. (May result in insulation resistance fall.)
- Heater Specification

1. Output : $33W \pm 7\%$

2. Voltage : $200V_{-10\%}^{+20\%}$ or $240V_{-20\%}^{+10\%}$

3. Insulating performance (after put it in water for 24h)

* Withstand voltage: AC1500V for 1 min. and the insulator no broke through.

* Insulation Resistance :100M Min. (Test with DC 500V gauge for 1 min)

- Caution

Even if the compressor does not work, also supply power to heater.

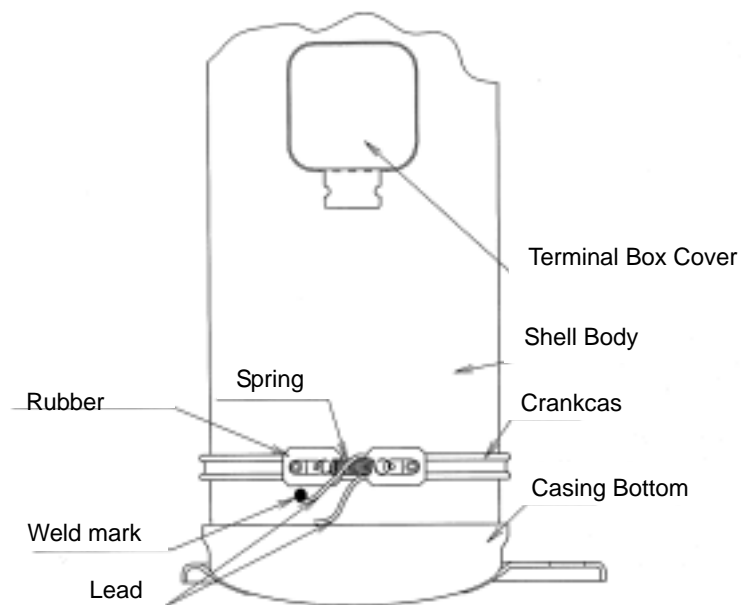
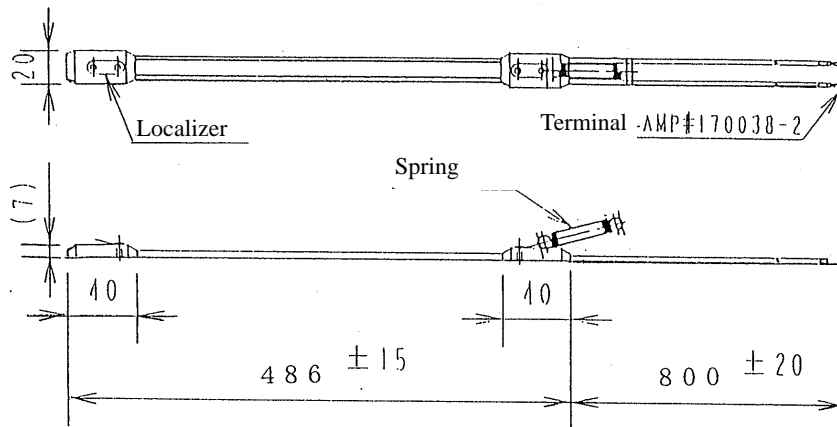

図番 DWG. NO.	DA 429-903 B		品名	数量*	記号	備考
	NO.	PART NAME	個数	寸法	REMARK	
	1	防振ゴム MOUNT. RUBBER	3	4		
	2	スペーサー SPAORER	3	4	細管 STEEL PIPE	
	3	座金 WASHER	3	4	客先調達 CUSTOMER'S ARRANGE	72.6
	4	ボルト M8x45 BOLT	3	4	客先調達 CUSTOMER'S ARRANGE	
	5	ナット M8 NUT	3	4	客先調達 CUSTOMER'S ARRANGE	

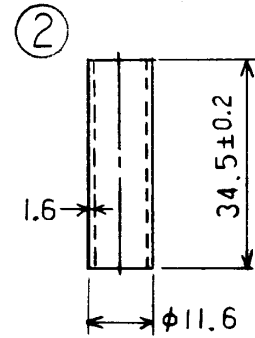
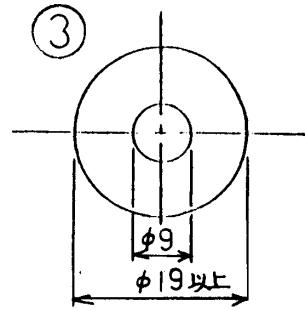

注) 圧縮機ニヨリ防振ゴムノ使用数ガ異ナル

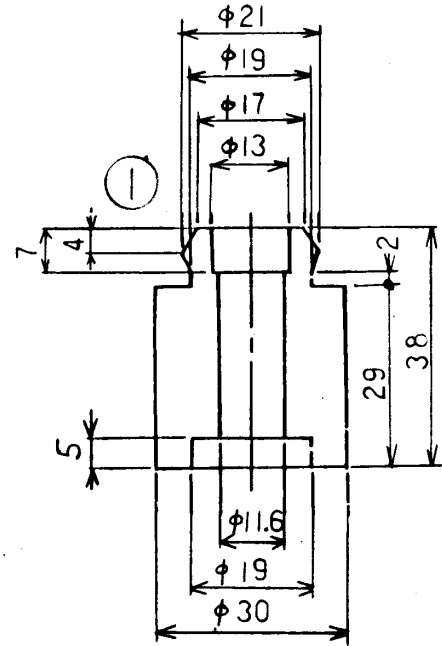
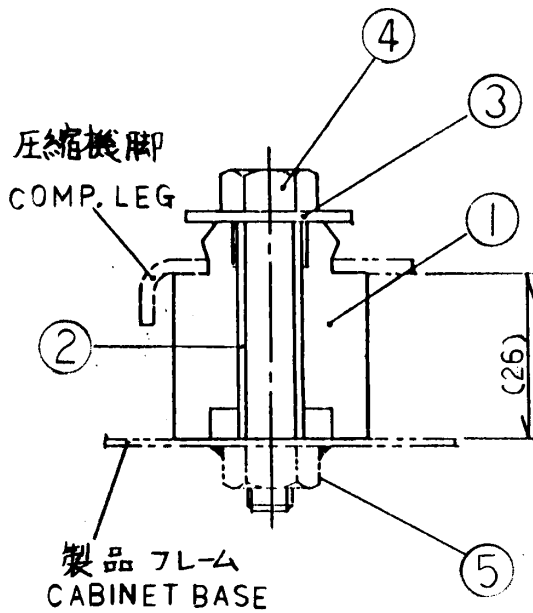

改正欄 REV.	
▲ 95.6.12	仕様変更→
	共通化17X
▲ 96.10.8	
	個数4並記

第3角法 3RD ANGLE PROJECTION	尺度 SCALE	♂	JT * A (B)	防振ゴム MOUNT. PARTS
作成日 DATE	YR 88	MO 9	DA	
承認 APPROVED	照査 CHECKED	設計 DESIGNED	製図 DRAWN	
配布先	松本 的場	西川	ダイキン工業株式会社 DAIKIN INDUSTRIES LTD	図番 DWG. NO. DA 429-903 B

Earthing Terminal

When earth with compressor earthing terminal, please operate as follow fig.

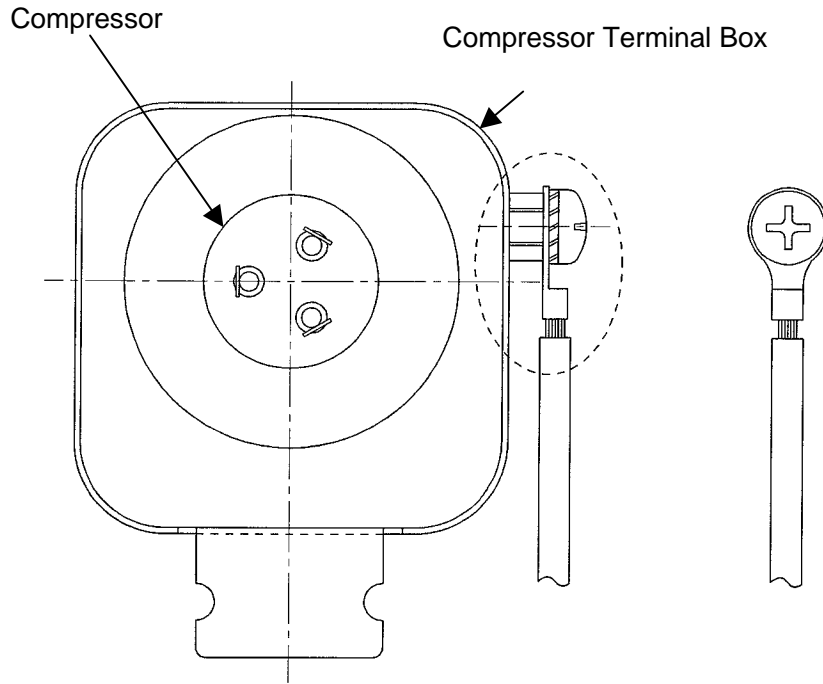

Earthing Terminal (Delivery under the M6 bolt and Terminal box is installed)

Earthing Terminal (Delivery under the M6 bolt and Terminal box is installed)

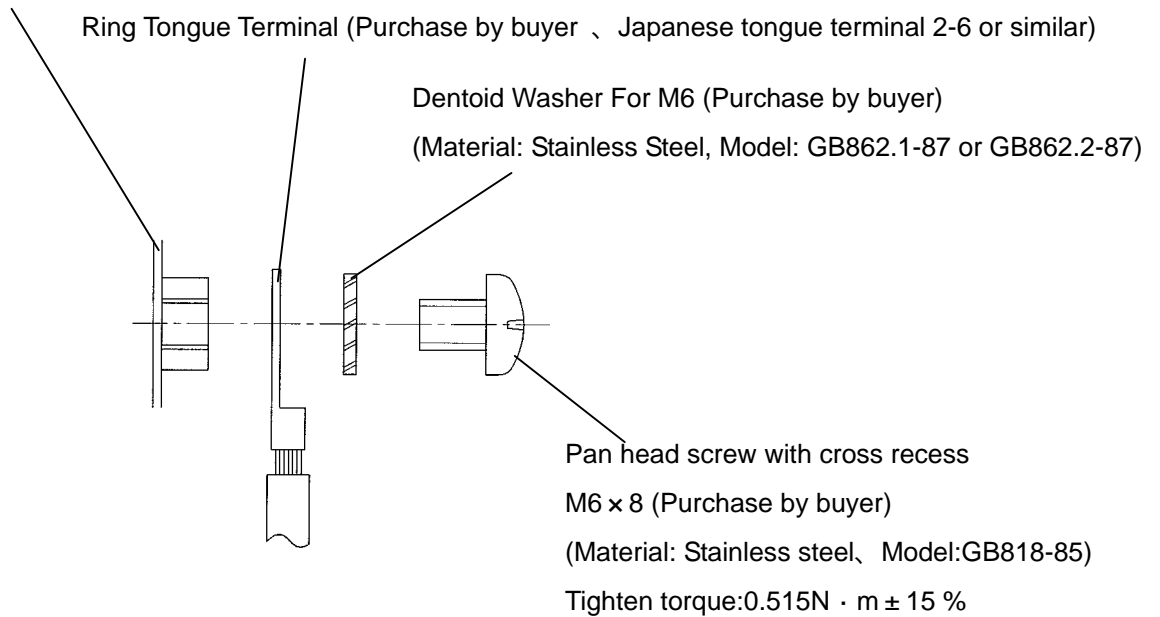

Detailed fig. of Earthing Terminal