

Compresseur / Compressor  
Code tension / Voltage code : F

# CAE4456Y

Froid commercial et industriel positif (HP)  
Commercial & industrial application (HBP)

220-240V / 50Hz - 1~

## R134a

## N° 213SS-F - ind f

Conditions <i>Conditions</i>	fréquence <i>frequency</i>	Prod frigorifique nominale / <i>nominal refrigerating capacity</i>			Puis. sonore <i>Sound level</i>
		Watts	Kcal/h	BTU/h	
Standard	50 Hz	1396	1201	4760	ISO 3745 / ISO 3743-1  56 dBA
Cecomaf	50 Hz	1239			

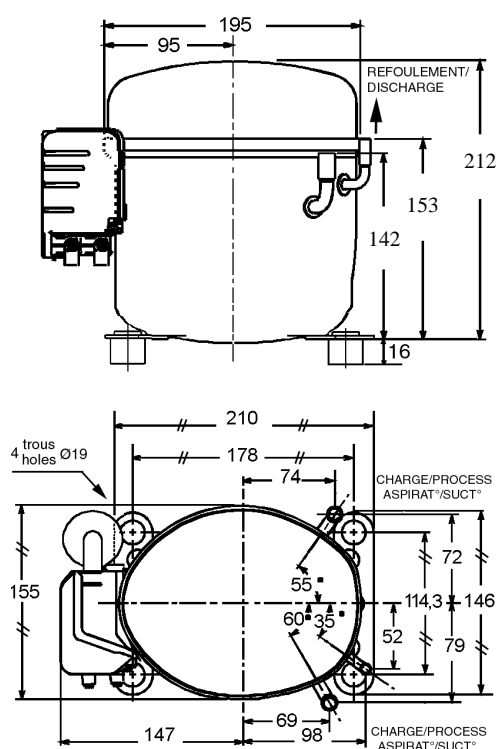

**Cylindrée / Displacement :** 16.2 cm<sup>3</sup>  
**Poids net / Net weight :** 12.7 Kg  
**Charge en huile / Oil charge :** 350 cm<sup>3</sup>  
**Type d'huile / Oil type :** P.O.E /  
**Détente / Expansion device :** Capillaire/Détendeur  
 Capillaire/Exp° valve  
**Refroidissement / Cooling :** Ventilé / Forced

**Résistance à 20° C / Windings resistances at 20° C**  
 Phase princ. / *Main Winding :* 3.7 Ohms  
 aux. / *Auxiliary Winding :* 19.7 Ohms

**Intensité / Current**  
 nom. / *Rated current RLA :* 4.1 A  
 max. / *Max current :* 5 A  
 dém. / *Start current LRA :* 19 A

**Ap. Electrique / Electrical equipment :** CSIR

**Protecteur / Overload :** MST28APK  
 Temporisation / *Time Check :* 7.5s - 14s / 12.2 A  
 T° ouverture / *Opening temp. :* 105° C  
 fermeture / *Closing temp. :* 61° C  
 Option / *optional :* T0691

**Relais Intensité / Current relay :** MTRPH56  
 enclenchement / *Pick up :* 11,6A  
 déclenchement / *Drop out :* 9,7A  
 Option / *optional :*

**Condensateur dém. / Start capacitor :** 64 µF / 330 V

Pour conduites Ø ext / *For tubing O.D.*

Aspiration <i>Suction</i>	Refolement <i>Discharge</i>	Charge <i>Process</i>
9.5 (3/8")	6.35 (1/4")	9.5 (3/8")

Les caractéristiques données dans cette fiche technique peuvent évoluer sans avis préalable, avec les améliorations que 'TECUMSEH EUROPE' entend toujours apporter à sa production.  
 'TECUMSEH EUROPE', in a constant endeavour to improve its products reserves the right to change any information contained in this leaflet without prior warning.



<b>CAE4456Y</b>	<b>Tension F : 220 - 240V 1~ 50 Hz</b>	<b>R134a</b>	<b>N°213SS-F</b>	<b>Ind f</b>
-----------------	--	--------------	------------------	--------------

Les performances sont données dans les <b>conditions Standard TE</b> :	Surchauffe :	11°K
	Sous refroidissement :	8.3°K
The performance data are in <b>Standard TE conditions</b> :	Superheat :	11°K
	Subcooling :	8.3°K

<b>50 Hz R134a</b>											
4   T condensation	5   T évaporation	(°C)	-25	-20	-15	-10	-5	0	5	10	15
<b>40</b>	1   P frigorifique	(W)	436	525	658	835	1057	1323	1634	1989	2388
	2   P absorbée	(W)	335	387	435	480	522	560	595	627	655
	3   I absorbée	(A)	3.2	3.3	3.39	3.48	3.57	3.66	3.75	3.84	3.93
<b>50</b>	1   P frigorifique	(W)		405	520	675	871	1106	1382	1698	2055
	2   P absorbée	(W)		384	438	492	545	597	648	699	748
	3   I absorbée	(A)		3.28	3.4	3.52	3.66	3.81	3.97	4.14	4.32
<b>55</b>	1   P frigorifique	(W)			452	596	778	998	1257	1553	1888
	2   P absorbée	(W)			440	498	557	616	675	735	794
	3   I absorbée	(A)			3.4	3.54	3.7	3.88	4.07	4.28	4.51
<b>60</b>	1   P frigorifique	(W)			383	516	685	890	1131	1408	1721
	2   P absorbée	(W)			441	504	569	634	702	770	841
	3   I absorbée	(A)			3.4	3.56	3.75	3.95	4.18	4.43	4.7
1 = refrigerating capacity      2 = watt input      3 = current      4 = condensing temperature      5 = evaporating temperature											

Nota : Les caractéristiques données dans cette fiche technique peuvent évoluer sans avis préalable, avec les améliorations que "TECUMSEH EUROPE" entend toujours apporter à sa production.

Note : "TECUMSEH EUROPE", in a constant endeavour to improve its products reserves the right to change any information contained in this leaflet without prior warning.